

Miele

Operating and installation instructions



Frost free fridge freezer with dynamic cooling

KFN 12823 SD

KFN 12923 SD

KFN 12924 SD

To avoid the risk of accidents or damage to the appliance, it is **essential** to read these instructions before it is installed or used for the first time.

en - GB

M.-Nr. 07 681 400

Contents

Guide to the appliance	4
Caring for the environment	6
Warning and Safety instructions	7
How to save energy	12
Switching on and off	13
To switch the refrigerator section off separately	14
Switching off for longer periods of time	14
The correct temperature	15
. . . in the refrigerator section	15
. . . in the freezer section	15
Setting the temperature	15
Temperature display	16
Temperature range	16
Alarm	17
Door alarm	17
Activating the alarm system	17
Switching the alarm off early	17
Super freeze and Dynamic cooling	18
Super freeze	18
Dynamic cooling 	19
Using the refrigerator efficiently	20
Different storage zones	20
Food which should not be stored in a refrigerator	21
When shopping for food	21
Storing food correctly	21
Fruit and vegetables	21
Unpacked meat and vegetables	22
Protein rich foods	22
Meat	22
Adjusting the interior fittings	23
Moving the shelves	23
Split shelf	23
Adjusting the door shelf/bottle shelf	23
Moving the bottle divider	23
Freezing and storing food	24
Maximum freezing capacity	24
Freezing fresh food	24

Contents

Storing frozen food	24
Home freezing	25
Hints on home freezing	25
Packing	25
Before placing food in the freezer	26
Placing food in the freezer	26
Freezing large items	26
Defrosting	26
Ice cubes	27
Cooling drinks	27
Freezer tray	27
Automatic defrost	28
Cleaning and care	29
Cleaning the outer casing, the interior and accessories	29
Ventilation gaps	29
Door seals	30
Problem solving guide	31
Noises	34
After Sales / Guarantee	35
Electrical connection	36
Installation	37
Location	37
Climate range	37
Ventilation	37
Installation	37
Aligning the appliance	38
Appliance dimensions	39
Changing the door hinging	40
Aligning the appliance doors	46
Building in the appliance	47

Guide to the appliance

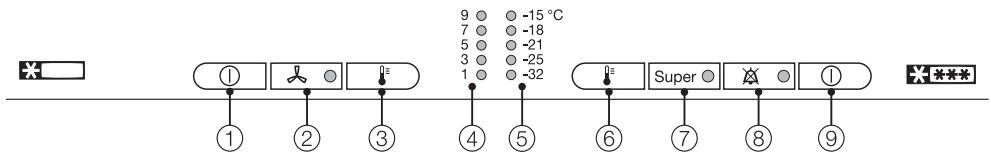

- ① On button for the whole appliance and On/Off button for independently switching the refrigerator section on and off
- ② Dynamic cooling button and indicator light
- ③ Refrigerator section temperature selector button
- ④ Refrigerator section temperature display
- ⑤ Freezer section temperature display
- ⑥ Freezer section temperature selector button
- ⑦ Super freeze button and indicator light
- ⑧ Alarm off button and indicator light
- ⑨ Master switch for switching the whole appliance on and off

Guide to the appliance

- ① Dynamic cooling fan
- ② Butter and cheese compartment
- ③ Interior lighting
- ④ Adjustable shelves
- ⑤ Egg tray
- ⑥ Door shelf
- ⑦ Bottle rack
- ⑧ Condensate channel and drain hole
- ⑨ Fruit and vegetable containers
- ⑩ Bottle divider*
- ⑪ Bottle shelf
- ⑫ Freezer drawers

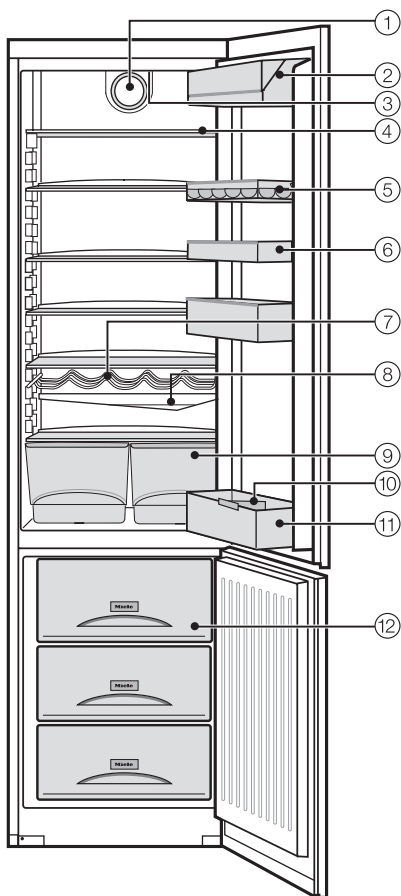

* Depending on model

Caring for the environment

Disposal of the packing material

The transport and protective packing has been selected from materials which are environmentally friendly for disposal, and can normally be recycled.

Ensure that any plastic wrappings, bags etc. are disposed of safely and kept out of the reach of babies and young children. Danger of suffocation!

Rather than just throwing these materials away, please ensure that they are recycled.

Disposal of your old appliance

Electrical and electronic appliances often contain materials which, if handled or disposed of incorrectly, could be potentially hazardous to human health and to the environment. They are, however, essential for the correct functioning of your appliance. Please do not therefore dispose of it with your household waste.

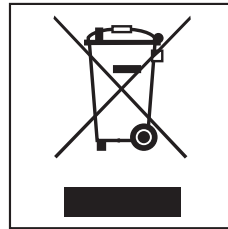

Please dispose of it at your local community waste collection / recycling centre or contact your dealer for advice. Ensure that it presents no danger to children while being stored for disposal.

It should be unplugged or disconnected from the mains electricity supply by a competent person.

Take care not to damage the pipework at the back of it before or during transportation to an authorised collection depot.

In this way, refrigerant in the pipework and oil in the compressor will be contained, and will not leak out into the environment.

Warning and Safety instructions

This appliance complies with all relevant local and national safety requirements. Improper use can, however, present a risk of both personal injury and material damage.

To avoid the risk of accidents and damage to the appliance, please read these instructions carefully before installation and before using it for the first time. They contain important notes on the installation, safety, operation and care of the appliance.

Keep these instructions in a safe place and pass them on to any future user.

Correct application

► This appliance is intended for domestic use only for the cool storage of food and drink as well as for storing deep frozen food, freezing fresh food and for preparing ice.

Any other usage is not supported by the manufacturer and could be dangerous. The manufacturer cannot be held liable for damage resulting from incorrect or improper use or operation.

► This appliance is not intended for use by persons (including children) with reduced physical, sensory or mental capabilities, or lack of experience and knowledge, unless they are supervised whilst using it, or have been shown how to use it by a person responsible for their safety.

Safety with children

► This appliance is not a toy! To avoid the risk of injury, do not allow children to play with it or near it, or to play with the controls. Neither should they be allowed to swing on the door. Please supervise young children whilst you are using it. Older children may only use the appliance when its operation has been clearly explained to them and they are able to use it safely, recognising the dangers of misuse.

Warning and Safety instructions

Technical safety

▶ Before setting up the appliance, check it for any externally visible damage. Do not install and use a damaged appliance.

A damaged appliance is dangerous.

▶ If the connection cable is faulty it must only be replaced by a service technician authorised by the manufacturer to protect the user from danger.

▶ This appliance contains the coolant Isobutane (R600a), a natural gas which is environmentally friendly. Although it is flammable, it does not damage the ozone layer and does not increase the greenhouse effect. The use of this coolant has, however, led to a slight increase in the noise level of the appliance. In addition to the noise of the compressor, you might be able to hear the coolant flowing around the system. This is unavoidable, but does not have any adverse effect on the performance of the appliance. Care must be taken during the transportation and installation of the appliance that no parts of the cooling system are damaged. Leaking coolant can damage the eyes.

In the event of any damage:

- avoid open flames and anything which creates a spark,
- disconnect from the mains,
- air the room in which the appliance is located for several minutes and
- contact the Service Department for advice.

▶ The more coolant there is in an appliance, the larger the room it should be installed in. In the event of a leakage, if the appliance is in a small room, there is the danger of combustible gases building up. For every 8 g of coolant at least 1 m³ of room space is required. The amount of coolant in the appliance is stated on the data plate inside the appliance.

▶ Safe operation of the appliance is only assured if it has been installed and connected in accordance with these operating and installation instructions.

▶ Before connecting the appliance, make sure that the connection data on the data plate (voltage and connected load) match the mains electricity supply.

This data must correspond in order to avoid the risk of damage to the appliance. Consult a qualified electrician if in any doubt.

▶ Do not connect the appliance to the mains electricity supply by a multi-socket unit or an extension lead. These do not guarantee the required safety of the appliance (e.g. danger of overheating).

Warning and Safety instructions

► The electrical safety of this appliance can only be guaranteed when continuity is complete between it and an effective earthing system which complies with current local and national safety regulations. It is most important that this basic safety requirement is present and tested regularly, and where there is any doubt, the household wiring system should be inspected by a qualified electrician. The manufacturer cannot be held liable for damage or injury caused by the lack of or inadequacy of an effective earthing system (e.g. electric shock).

► Installation, maintenance and repairs may only be carried out by a suitably qualified and competent person in strict accordance with current national and local safety regulations. Repairs and other work by unqualified persons could be dangerous. The manufacturer cannot be held liable for unauthorised work.

► While the appliance is under guarantee, repairs should only be undertaken by a service technician authorised by the manufacturer. Otherwise the guarantee will be invalidated.

► The appliance must be isolated from the electricity supply during installation, maintenance and repair work. The appliance is only completely isolated from the electricity supply when:

- it has been switched off at the socket and the plug has been withdrawn, or
- the fuse from the fused spur connection unit has been withdrawn, or
- the mains fuse has been disconnected, or
- the screw-out fuse has been removed (in countries where this is applicable).

► Faulty components must only be replaced by genuine Miele original spare parts. The manufacturer can only guarantee the safety of the appliance when Miele replacement parts are used.

► This appliance may only be used in mobile installations such as ships, if a risk assessment of the installation has been carried out by a suitably qualified engineer.

► In countries where there are areas which may be subject to infestation by cockroaches or other vermin, pay particular attention to keeping the appliance and its surroundings in a clean condition at all times. Any damage which may be caused by cockroaches or other vermin will not be covered by the guarantee.

Warning and Safety instructions

Correct use

- ▶ Never handle frozen food with wet hands. Your hands may freeze to the frozen food. Danger of frost burn.
- ▶ Do not take ice cubes out with your bare hands and never place ice cubes or ice lollies in your mouth straight from the freezer.
The very low temperature of the frozen ice or lollies can cause frost burn to the lips and tongue.
- ▶ Do not refreeze thawed or partially thawed food. Defrosted food should be used up as quickly as possible, as food soon loses its nutritional value and goes off. Defrosted food may only be re-frozen after it has been cooked.
- ▶ Do not store explosive materials in the appliance or any products containing propellants (e.g. spray cans). Thermostats switching on may produce sparks which could present a fire hazard. Flammable compounds could explode.
- ▶ Do not operate any electrical equipment (e.g. an electric ice-cream maker) inside the appliance. Danger of sparking and explosion.
- ▶ If storing alcohol with a high percentage proof, make sure it is tightly closed and stored upright.
Danger of explosion.

- ▶ Do not store cans or bottles containing carbonated drinks or liquids which could freeze in the freezer. The cans or bottles could explode. Danger of injury and damage to the appliance.
- ▶ When cooling drinks quickly in the freezer, make sure bottles are not left in for more than one hour; otherwise they could burst, resulting in injury or damage.
- ▶ Observe the "use by" dates given on food to avoid the risk of food poisoning. Storage times will depend on several factors, including the freshness and quality of the food as well as the temperature at which it is stored. Follow the instructions given on the food manufacturer's packaging regarding storage conditions and "use-by" dates.
- ▶ Do not use sharp edged objects to
 - remove frost and ice,
 - separate frozen foods and remove ice trays.They will damage the evaporator, causing irreversible damage to the appliance.
- ▶ Do not place electric heaters or candles in the appliance to defrost it. These can damage the plastic parts.

Warning and Safety instructions

▶ Do not use defrosting sprays or de-icers, as they might contain substances which could damage the plastic parts or which could cause the build-up of gases and pose a danger to health.

▶ Do not use any oils or grease on the door seals, as these will cause the seals to deteriorate and become porous with time.

▶ Do not store cooking oil in the refrigerator door. Traces of oil can cause stress cracks to occur in the plastic components in the door.

▶ Do not block the ventilation gaps in the appliance as this would impair the efficiency of the appliance, increase the electricity consumption and could cause damage to the appliance.

▶ The appliance is designed for use within certain climate ranges (ambient temperatures), and should not be used outside this range. The climate range for your appliance is stated on the data plate inside the appliance. Installing it in a room with too low an ambient temperature, e.g. a garage, can lead to the appliance switching off for longer periods so that it cannot maintain the required temperature.

▶ Do not use a steam-cleaning appliance to defrost or clean this appliance. Steam could reach the electrical components and cause a short circuit.

Disposal of your old appliance

▶ Before disposing of an old appliance, first make the door latch or lock unusable.

This way you will prevent children from accidentally locking themselves in and endangering their lives.

▶ Be careful not to damage any part of the pipework whilst awaiting disposal, e.g. by

- puncturing the refrigerant channels in the evaporator.
- bending any pipework.
- scratching the surface coating.

Splashes of refrigerant can damage the eyes.

The manufacturer cannot be held liable for damage caused by non-compliance with these Warning and Safety instructions.

How to save energy

	Normal energy consumption	Increased energy consumption
Installation site	In a ventilated room.	In an enclosed, unventilated room.
	Protected from direct sunlight.	In direct sunlight.
	Not situated near to a heat source (radiator, oven).	Situated near to a heat source (radiator, oven).
	Where the ideal ambient room temperature is approx. 20°C.	Where there is a high ambient room temperature.
Temperature setting with a thermostat which is approximate (set in stages).	With a medium setting of 2 to 3.	With a high setting: the lower the temperature in the compartment, the higher the energy consumption.
Temperature setting with a thermostat which is exact to the degree (digital display).	Cellar section 8 to 12°C	On appliances with winter setting, please make sure that the winter setting is switched off when the ambient temperature is warmer than 16 °C.
	Refrigerator section 4 to 5 °C	
	PerfectFresh zone just above 0 °C	
	Freezer section -18°C	
	Wine storage section 10 to 12 °C	
Use	Only open the doors when necessary and for as short a time as possible.	Frequent opening of the doors for long periods will cause a loss of coldness.
	Store food in an organised way.	If food is not stored in an organised way, searching for an item will mean the door is open for longer.
	Allow hot food and drinks to cool down before placing them in the appliance.	Placing hot food in the appliance will cause the compressor to run for a long time, as the appliance will have to work harder to lower the temperature.
	Store food covered or packaged.	The evaporation or condensation of liquids will cause a loss of coldness in the refrigerator.
	Place frozen food in the refrigerator to defrost.	
	Do not over-fill the appliance to allow air to circulate.	
Defrosting	Defrost the freezer compartment when a layer of ice 0.5 cm thick has built up.	A layer of ice hinders the cold from reaching the frozen food, and causes an increase in energy consumption.

Before using for the first time

The stainless steel trim to the interior shelves and the door shelves has a layer of protective foil to prevent damage during transportation. Please remove this carefully after installation.

- Clean the inside of the appliance and the accessories with lukewarm water and a little washing-up liquid, and then dry with a soft cloth.
- Carefully remove the protective foil from the stainless steel trim.

Important:

To ensure the correct functioning of the appliance, let it stand for between 1½ and 2 hours after transporting it to its final location before connecting it to the mains.

Switching on

The refrigerator and freezer sections are switched on together by pressing the master switch on the right hand side of the control panel, or by pressing the On/Off button on the left hand side of the control panel.

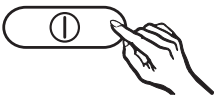

- Press the master switch on the right hand side of the control panel.

The temperature display for the refrigerator section will show the selected temperature setting. The temperature display for the freezer and the alarm indicator light will flash until

the freezer section has cooled down to the correct temperature for freezing.

The appliance will start cooling down and the interior light in the refrigerator section will come on if you open the door.

Allow the appliance to run for a few hours before placing food in it. This will ensure that the temperature is sufficiently low.

Cool pack

Place the cool pack in the top drawer of the freezer. The cool pack will be at its most effective after it has been in the freezer for approx. 24 hours.

Switching off

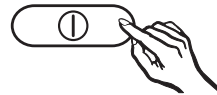

- Press the master switch on the right hand side of the control panel until both temperature displays go out.

The interior light will not come on when you open the door and the cooling process will be switched off.

Switching on and off

To switch the refrigerator section off separately

The refrigerator section can be switched off without having to switch off the freezer section. This is useful e.g. whilst on holiday.

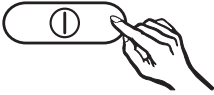

- Press the master switch on the right hand side of the control panel.

The temperature display will light up for both the refrigerator and the freezer sections.

- Press the On/Off button for the refrigerator section on the left hand side of the control panel until the temperature display for the refrigerator section goes out.

The refrigerator section is now switched off.

The temperature display for the freezer section will remain lit up.

To switch the refrigerator section on again

- Press the On/Off button on the left hand side of the control panel again.

The refrigerator section temperature display will light up. The refrigerator section will start cooling. The interior light will come on when the door is opened.

Switching off for longer periods of time

If the appliance is not going to be used for a longer period of time, e.g. whilst on holiday:

- switch the appliance off,
- switch off at the wall socket and withdraw the plug,
- clean the appliance out and
- leave the doors ajar to air it.

If, during a long absence, the appliance is switched off but not cleaned out and the doors are left shut, there is a danger of mould and odours building up inside the appliance.

The correct temperature

It is very important to set the correct temperature for storing food in the appliance. Micro-organisms will cause food which is not stored at the correct temperature to deteriorate rapidly. Temperature influences the growth rate of these micro-organisms. Reducing the temperature reduces their growth rate.

The temperature in the appliance will rise:

- the more often the door is opened and the longer it is kept open,
- the more food that is stored in it,
- the warmer the food is which is being put into it,
- the higher the ambient temperature surrounding the appliance.

The appliance is designed for use in specific ambient temperatures (climate ranges). Do not use in ambient temperatures for which it is not designed.

. . . in the refrigerator section

We recommend a temperature of **5 °C** in the middle of the refrigerator.

. . . in the freezer section

To freeze fresh food and to store frozen food for a long time, a temperature of **-18 °C** is required. At this temperature the growth of micro-organisms is generally halted. As soon as the temperature rises above -10 °C, the micro-organisms become active in the food again so that it cannot be kept as long. For this reason, partially defrosted or defrosted food must not be re-frozen. Food may be re-frozen once it has been cooked, as the high temperatures achieved when cooking destroy most micro-organisms.

Setting the temperature

The temperature is set in each zone by using the respective temperature button.

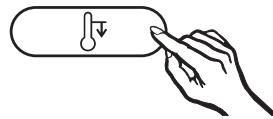

- Press the temperature button repeatedly until the indicator light for the temperature you want lights up in the display.

The temperature changes each time you press the button.

The temperature being set will flash in the display as you do this.

The correct temperature

Temperature display

The temperature display on the control panel always shows the **required** temperature.

Temperature range

The temperature can be adjusted:

- In the refrigerator section from 1 °C to 9 °C
- In the freezer section from -15 °C to -32 °C.

The ambient temperature in the room and the installation location can affect the time it takes for the appliance to reach the lowest temperature. If the ambient temperature is too high, the appliance may not reach the lowest temperature.

The **temperature display will flash** if

- the temperature in the appliance is not within the possible temperature range,
- a different temperature is being set,
- the temperature in the appliance has risen by several degrees, indicating that the appliance is warming up too much.

This loss of coldness is no cause for concern in the following circumstances:

- when the door has been left open for a while, e.g. for removing or storing a large amount of food,
- when fresh food is being frozen.

However, if the temperature in the freezer section remains above -18 °C for a long time, check that the frozen food has not started to defrost. If it has started thawing, check that the food is safe to use and if it is, use it as quickly as possible.

Your appliance has been fitted with a warning system which ensures that the temperature in the freezer section cannot rise unnoticed.

An alarm will sound and at the same time the temperature display for the freezer section will flash if the temperature becomes too warm. The temperature the appliance is set at determines the temperature the appliance recognises as being too warm.

The alarm will sound and the alarm indicator light will flash,

- if the freezer door has been left open for a while, e.g. in order to load, to re-arrange or to take food out.
- when freezing large amounts of food at once.

Door alarm

If either of the doors is left open for more than approx. 60 seconds, the alarm will sound.

Activating the alarm system

The alarm system is always active. It does not have to be switched on manually.

Switching the alarm off early

Once the set temperature has been reached in the freezer, the alarm switches off and the temperature display stops flashing and lights up constantly. However, if the noise disturbs you, you can switch the alarm off before this if you wish.

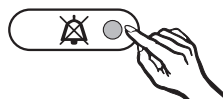

- Press the alarm off button.

The alarm will stop. The temperature display will continue to flash until the set temperature has been reached.

The display then stops flashing and lights up constantly. The alarm system is now fully active once more.

Super freeze and Dynamic cooling

Super freeze

Switch the Super freeze function on before putting fresh food into the freezer.

This helps food to freeze quickly and retain its nutrients, vitamins, flavours and appearance.

Super freeze is not necessary:

- when placing food in the freezer that is already frozen.
- when freezing up to 2 kg fresh food daily.

Switching on Super freeze

When freezing small quantities of food in the freezer, the Super freeze function should be switched on **6 hours beforehand**. When freezing **the maximum load of food** the Super freeze function should be switched on **24 hours beforehand**.

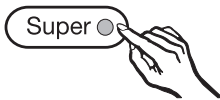

- Press the Super freeze button. The Super freeze indicator light will come on.

The appliance works at full power to lower the temperature in the appliance.

Switching off Super freeze

The Super freeze function will switch off automatically after approx. 65 hours. The indicator light will go out and the appliance will run at normal power again.

To save energy the Super freeze function can be switched off once a **constant** temperature of -18°C or colder has been reached in the freezer.

- Press the Super freeze button. The Super freeze indicator light will go out, and the appliance will continue to operate at normal power.

Super freeze and Dynamic cooling

Dynamic cooling

When the Dynamic cooling function is not switched on, the natural circulation of air in the appliance will cause different temperature zones in the refrigerator as the cold, heavy air will sink to the lowest section of the appliance. You should bear this in mind when placing food in the appliance (see "Using the refrigerator efficiently"). However, if you are placing a large amount of food in the refrigerator at any one time, it is a good idea to switch on Dynamic cooling. This way you can distribute the temperature inside the appliance to all areas more evenly so that all the food will be chilled to about the same degree.

The temperature is set as normal with the temperature control.

Dynamic cooling should also be selected when:

- the ambient temperature in the room is high (above approx. 30 °C), and
- the room humidity level is high.

Switching on Dynamic cooling

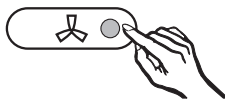

- Press the Dynamic cooling button. The Dynamic cooling indicator light will come on.

Make sure the fan at the back of the appliance is not restricted to ensure unhindered air circulation.

Switching off Dynamic cooling

- Press the Dynamic cooling button . The Dynamic cooling indicator light will go out.

The fan automatically switches off when the door is open.

Using the refrigerator efficiently

Different storage zones

Due to the natural circulation of the air in the appliance, there are different temperature zones in the refrigerator. Cold, heavy air sinks to the lowest section of the appliance. Make use of the different zones when placing food in the appliance.

This appliance has Dynamic cooling, which helps to keep an even temperature when the fan is running. When Dynamic cooling is switched on, the difference between the various zones is less pronounced.

Warmest area

The warmest area is in the top section of the door. Use this for storing butter and cheese.

Coldest area

The coldest area in a refrigerator is directly above the vegetable containers.

Use this for all delicate and highly perishable food, e.g.

- fish, meat, poultry,
- sausage products, ready meals,
- dishes or baked goods containing eggs or cream,
- fresh dough, cake mixtures, pizza or quiche dough,
- soft cheese and other dairy products,

- pre-packed vegetables and other fresh food with a label stating it should be kept at a temperature of approx. 4 °C.

Do not store explosive materials in the appliance or any products containing propellants (e.g. spray cans). Danger of explosion.

If storing alcohol with a high percentage proof, make sure it is tightly closed, and store upright.

Do not store cooking oil in the refrigerator door. Traces of oil can cause stress cracks to occur in the plastic components in the door.

Food must not touch the back wall of the refrigerator, as it may freeze to the back wall.

To allow air to circulate efficiently, do not pack food too closely together in the refrigerator. Do not cover the fan in the rear wall of the refrigerator, as this is essential for keeping the appliance cool.

Using the refrigerator efficiently

Food which should not be stored in a refrigerator

Not all food is suitable for refrigeration, as some food is sensitive to cold. Cucumbers, for example, become glassy, aubergines bitter and potatoes sweet. Tomatoes and oranges lose their aroma, and the peel on citrus fruit hardens.

Food which should not be stored in a refrigerator includes:

- pineapple, pomegranate, bananas, avocado, mangos, papaya, passion fruit, citrus fruit
- fruit which is not yet ripe
- aubergines/egg plant, cucumbers, potatoes, peppers/capsicum, tomatoes, courgettes,
- some hard cheeses, e.g. Parmesan

When shopping for food

The freshness of food when first placed in the appliance is an important factor in determining how long it stays fresh, and how long it can be kept in the refrigerator. Time out of the refrigerator, e.g. during transportation, should be kept to a minimum. For example, do not allow food to stay in a hot car for too long. Once food has started to deteriorate, this process cannot be reversed. As little as two hours outside the refrigerator can cause food to start deteriorating.

Storing food correctly

Food should generally be stored covered or packaged. This will prevent food smells from affecting other foods, food from drying out, and also any cross-contamination of bacteria. The growth of bacteria, such as salmonella, can be avoided by setting the correct temperature and maintaining good standards of hygiene.

Fruit and vegetables

Fruit and vegetables may be stored loose in the vegetable containers. Please be aware that not all types of fruit and vegetables are suitable for storing in the same container. Aromas and flavours can transfer from one type of food to another (e.g. carrots absorb the smell and flavour of onions very easily). Some food also gives off a natural gas (ethylene) which speeds up the rate at which other food perishes.

– **Examples of fruit and vegetables which produce a large amount of this natural gas are:**

Apples, apricots, pears, nectarines, peaches, plums, avocado, figs, blueberries, melons and beans.

Using the refrigerator efficiently

– **Examples of fruit and vegetables which react strongly to the natural gases given off by other types of fruit and vegetables are:**

Kiwis, broccoli, cauliflower, brussels sprouts, mangos, honeydew melons, apples, apricots, cucumbers, tomatoes, pears, nectarines and peaches.

Example: Broccoli should not be stored with apples, as apples produce a large amount of natural gas to which broccoli is very sensitive. The result is a shorter than expected storage time for the broccoli.

Unpacked meat and vegetables

Unpackaged meat and vegetables should be stored separately. To avoid any microbiological cross-contamination, these foods may only be stored together if they are wrapped.

Protein rich foods

Please note that foods rich in protein deteriorate faster than others. Shellfish, for example, deteriorates faster than fish, and fish deteriorates faster than meat.

Meat

Meat should be stored unwrapped. (Undo wrappings slightly to leave meat loosely covered, and leave containers open). This permits air to circulate around the meat, allowing the surface to dry slightly, which helps prevent the growth of bacteria. To prevent the risk of bacterial cross-contamination and meat deteriorating, do not let one type of meat come into direct contact with another type.

Adjusting the interior fittings

Moving the shelves

The shelves can be adjusted according to the height of the food.

- Raise the shelf, and pull it forwards slightly until the notch at the side is in line with the shelf support. It can then be raised or lowered to the required level.

The raised edge at the back must face upwards to prevent food from touching the back of the appliance and freezing to it.

Stoppers prevent the shelves from being dislodged by mistake.

Split shelf

In order to accommodate tall items in the appliance, one of the shelves is divided. The front section can be pushed under the rear section.

- Push the rear half of the glass shelf up slightly from below.
- At the same time, pull the front half of the glass shelf forwards slightly and then push it carefully under the rear half.

To move the split shelf:

- Take both halves of the split glass shelf out,

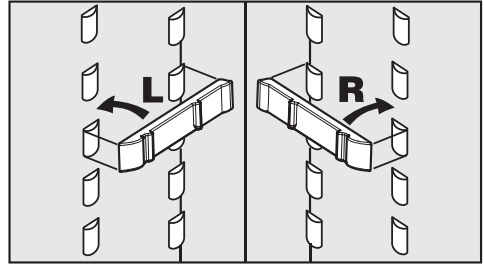

- fit the two brackets onto the supports on either side at the required height,
- and push the glass shelves in one after the other.
The shelf with the raised edge must be at the back.

Adjusting the door shelf/bottle shelf

- Push the door/bottle shelf upwards, then remove it by pulling it forwards.
- Replace the door/bottle shelf at the required position. Ensure that it is securely pushed back into position.

Moving the bottle divider

(depending on model)

The bottle divider can be moved to the left or right to ensure that bottles are held securely in position when the door is opened and shut.

The bottle divider can be removed completely (e.g. for cleaning).

- To do this, push up the front edge of the bottle divider, and disengage it.

Freezing and storing food

Maximum freezing capacity

To ensure that fresh food placed in the freezer freezes through to the core as quickly as possible, the maximum freezing capacity must not be exceeded. The maximum freezing capacity for freezing within a 24-hour period is given on the data plate: "Freezing capacitykg/24 hrs".

The maximum freezing capacity given on the data plate has been calculated according to DIN EN ISO 15502 Standard.

Freezing fresh food

Fresh food should be frozen as quickly as possible. This way the nutritional value of the food, its vitamin content, appearance and taste are not impaired.

Food which takes a long time to freeze will lose more water from its cells, which then shrink.

During the defrosting process, only some of this water is reabsorbed by the cells; the rest collects around the food.

If food is frozen quickly, the cells have less time to lose moisture, so they shrink less. As there is not so much moisture loss, it is easier for the food to reabsorb it during the defrosting process, and very little water collects around the defrosted food.

Storing frozen food

When buying frozen food to store in your freezer compartment, check

- that the packaging is not damaged,
 - the use-by date,
 - the temperature at which the frozen food is being stored in the shop. The length of time it can be kept is reduced if it has been stored at a temperature warmer than -18 °C.
- Buy frozen food once you have finished the rest of your shopping, and wrap it in newspaper or use a cool bag or cool box to transport it.
 - Store it in the freezer as soon as possible.

Never re-freeze partially or fully defrosted food. Consume defrosted food as soon as possible as it will lose its nutritional value and spoil if left for too long. Defrosted food may only be re-frozen after it has been cooked.

Home freezing

Only freeze fresh food which is in a good condition.

Hints on home freezing

- The following types of food **are suitable** for freezing:
Fresh meat, poultry, game, fish, vegetables, herbs, fresh fruit, dairy products, pastry, leftovers, egg yolks, egg whites and a range of pre-cooked meals.
- The following types of food **are not suitable** for freezing:
Grapes, lettuce, radishes, sour cream, mayonnaise, eggs in their shells, onions, whole raw apples and pears.
- To retain colour, taste and vitamin C, vegetables should be blanched after they have been trimmed and washed.
To blanch: bring a large saucepan of water to the boil, immerse the vegetables in the fast boiling water for 2-3 minutes, depending on variety. Remove, and plunge into ice-cold water to cool quickly. Drain and pack ready for freezing.
- Lean meat freezes better than fatty meat, and can be stored for considerably longer.
- To prevent chops, steaks, cutlets or rolled meat from freezing together in solid blocks when packed, separate with a sheet of plastic freezer film.
- Do not season fresh foods or blanched vegetables before freezing. Only season cooked food

lightly before freezing, but care should be taken as the taste of some spices alters when frozen.

- Do not place hot foods or drinks in the freezer. This causes already frozen food to thaw, and increases the energy consumption considerably. Allow hot foods and drinks to cool down before placing them in the freezer.

Packing

- Freeze food in portions.

Unsuitable packing material

- wrapping paper
- grease-proof paper
- cellophane
- bin bags
- plastic carrier bags

Suitable packing material

- plastic freezer film
- freezer bags
- aluminium foil
- freezer containers

- Expel as much air as possible from bags etc. before sealing them, to prevent freezer-burn on food.
- Close the packaging tightly with
 - rubber bands
 - plastic clips
 - string or bag ties
 - freezer tape.

Freezer bags may also be sealed using home heat sealing kits.

- Make a note of the contents and the date of freezing on the packaging.

Freezing and storing food

Before placing food in the freezer

- When freezing more than 2 kg of fresh food, switch on the Super freeze function for some time before placing the food in the freezer (see "Super freeze").

This helps food that is already in the freezer section to stay frozen.

Placing food in the freezer

Food to be frozen can be placed anywhere in the freezer.

Large quantities should be placed directly on the glass cold plates to freeze the food quickly. To do this first take out the top two freezer drawers. When removing the top drawer, make sure that you do not block the ventilation slits in the back wall of the appliance. They are important for trouble-free operation of the appliance.

The lowest freezer drawer must always remain in the appliance.

Each drawer and glass cold plate can take a maximum of 25 kg.

- Place the food flat in the bottom of the freezer drawers or on the glass cold plates so that it freezes through to the core as quickly as possible.
- Make sure that the packaging and containers are dry to prevent them sticking together when frozen.

When freezing, make sure that food already frozen does not come into contact with fresh food being frozen as this could cause the frozen food to begin to defrost.

Freezing large items

If you wish to freeze large items such as a turkey or game, the glass cold plates between the drawers can also be removed. To do this:

- Remove the top two freezer drawers, and carefully lift and slide out the glass cold plates.

Defrosting

Frozen food can be defrosted in different ways:

- in a microwave oven,
- in an oven using the "Fan" or "Defrost" setting,
- at room temperature,
- in the refrigerator (the cold given off by the frozen food helps to keep the other food cold),
- in a steam oven.

Poultry It is particularly important to observe food hygiene rules when defrosting poultry. Do not use the liquid from defrosted poultry. Pour it away and wash the container it was in, the sink and your hands. Danger of salmonella poisoning.

Fruit should be defrosted at room temperature in its packaging, or in a covered bowl.

Freezing and storing food

Most vegetables can be cooked while still frozen. Just put straight into boiling water or hot fat. The cooking time is slightly less than that of fresh vegetables due to changes in the cell structure.

Never re-freeze partially or fully defrosted food. Consume defrosted food as soon as possible as it will lose its nutritional value and spoil if left for too long. Defrosted food may only be re-frozen after it has been cooked.

Ice cubes

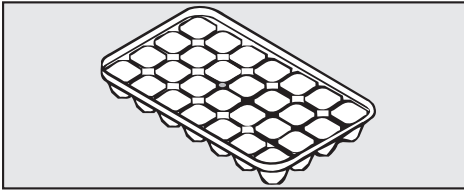

- Fill the ice tray three quarters full with water, and place it in the bottom of one of the drawers.
- Once frozen, use a blunt instrument, for example a spoon handle, to remove the ice tray from the freezer.
- Ice cubes can be removed easily from the tray by twisting the tray gently or by holding it under cold running water for a short while.

Cooling drinks

When placing bottles in the freezer section for rapid cooling, **make sure they are not left in for more than one hour** as they could burst.

Freezer tray

The freezer tray is useful for freezing small items such as berries, herbs and vegetables. They can be frozen individually and therefore maintain their shape when defrosted.

- Space the food out loosely on the tray.

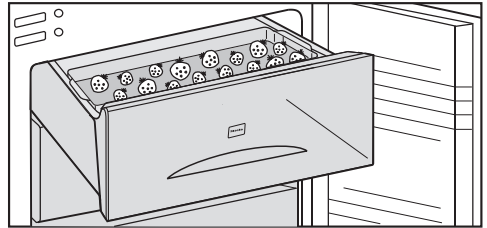

- Hang the tray in one of the upper freezer drawers.

Leave the food for 10-12 hours to freeze thoroughly on the tray. Transfer it to a freezer bag or suitable container once frozen. Place the bag or container in the freezer drawer.

Automatic defrost

Refrigerator section

The refrigerator defrosts automatically.

Condensate and frost can build up on the back wall of the refrigerator section whilst it is in use. You do not need to remove this, as it will defrost and evaporate automatically with the warmth generated by the appliance.

The condensate is drained away via a channel and drain hole into an evaporation system at the back of the appliance.

Ensure that the condensate channel and drain hole are kept clean and are never blocked so that condensate can flow away without hindrance.

Freezer section

This appliance is equipped with a "Frost free" system. The freezer section defrosts automatically.

The moisture generated in the appliance collects on the condenser and is automatically defrosted and dissipated by the condenser from time to time.

This automatic defrosting system enables the freezer section to remain permanently ice-free, however, the food stored in the freezer section will not defrost.

- A range of Miele branded cleaning and conditioning agents including a microfibre "E-Cloth" is available from the Miele UK Spare Parts Department, or via the internet at www.miele-shop.com.

Never use cleaning agents containing abrasive substances such as sand, soda, acids chlorides or chemical solvents. "Non-abrasive" cleaning agents are also unsuitable as they can cause matt areas to appear.

Do not let water get into the electronic unit, into the light or into the ventilation grille.

Do not let water get into the drainage channel and drain hole when cleaning.

Do not use steam cleaning apparatus to clean the appliance. Steam could reach the electrical components and cause a short circuit.

The data plate located inside the appliance must not be removed. It contains information which is required in the event of a service call.

Before cleaning

- Switch the appliance off, switch off at the wall socket and withdraw the plug.
- Take any food out of the appliance and store it in a cool place.
- Take out any removable parts, e.g. shelves, for cleaning.

Cleaning the outer casing, the interior and accessories

Use warm water with a little washing-up liquid. Wash all accessories and drawers by hand only. Do not wash in a dishwasher.

- Clean the appliance at least once a month.
- Clean the condensate channel and drain hole frequently, so that condensate can drain away unhindered. Use a straw or similar to clear the drain if necessary.
- After cleaning wipe the outer casing, interior and accessories with a damp cloth and dry with a soft cloth. Leave the doors open to air the appliance for a short while.

Ventilation gaps

- The ventilation gaps should be cleaned on a regular basis with a brush or vacuum cleaner. A build up of dust will increase the appliance's energy consumption.

Cleaning and care

Metal grille at the back of the appliance

The metal grille at the back of the appliance (heat exchanger) should be dusted at least once a year. A build-up of dust will increase the energy consumption of the appliance.

- When cleaning the grille, make sure that the pipework and other components do not get broken or damaged in any way.

Door seals

Do not use any oils or grease on the door seals as these will cause the seals to deteriorate and become porous over time.

The door seals should be cleaned regularly with clean water and then wiped dry with a soft cloth.

After cleaning

- Replace all shelves and accessories in the refrigerator section.
- Place food back in the refrigerator section, close the appliance doors, insert the plug in the socket and switch the appliance on.
- Switch on the Super freeze function so that the freezer section can cool down quickly.
- Once the temperature in the freezer has reached the required temperature, place the food back in the freezer.
- Switch off Super freeze by pressing the Super freeze button.

Repairs to electrical appliances should only be carried out by a suitably qualified and competent person in strict accordance with current local and national safety regulations. Repairs and other work by unqualified persons could be dangerous. The manufacturer cannot be held liable for unauthorised work.

What to do if . . .

. . . the appliance does not get cool.

- Check whether the appliance has been switched on. The temperature display must be lit up.
- Check that the plug is correctly inserted into the socket and switched on.
- Check that the fuse is not defective and that the mains fuse has not tripped. If it has, contact the Miele Service Department.

. . . the temperature in the refrigerator section or freezer section is too low.

- Set a warmer temperature.
- The Super freeze function is still on and the Super freeze indicator light is on.
The Super freeze function switches itself off automatically after approx. 65 hours.
- Check that the doors have been closed properly.
- Has a large amount of fresh food been frozen at the same time?

This makes the compressor run for longer, causing the temperature in the refrigerator section to fall automatically.

. . . the compressor is switching in too frequently and for too long.

- Check whether the ventilation gaps have been covered over or become dusty.
- Check whether the metal grille (heat exchanger) at the back of the appliance has become too dusty.
- The doors have been opened too frequently, or a large amount of fresh food has been put in at once for freezing.
- Check that the doors have been closed properly.

. . . the frozen food is thawing because the freezer section is too warm.

- Is the room temperature lower than the ambient temperature for which the appliance is designed?

If so, raise the temperature of the room.

Operating in a room which is too cold will cause the cooling system to switch off for too long, causing the freezer section to become too warm.

Problem solving guide

... food has frozen together.

Use a blunt instrument, e.g. a spoon handle or plastic scraper, to prise it apart carefully.

... the door to the freezer section will not open because it has been opened and closed too many times in succession.

This is not a fault. The suction caused by opening and closing the door is preventing the door from opening. Wait a few minutes and then try again. It should now open without force.

.. the alarm sounds.

Has one of the the appliance doors been open for longer than 60 seconds?

- Close the door.

... the alarm sounds and the freezer section temperature display flashes.

The freezer section temperature has risen above the set temperature because

- the freezer section door has been opened too frequently, or large amounts of fresh food have been put in at once for freezing.
- the ventilation gaps are blocked.

Once the problem has been resolved the freezer section temperature display will light up constantly and the alarm will stop.

... the Super freeze indicator light and one of the temperature display lights are flashing at the same time.

There is a fault. Call the Service Department.

... the interior lighting in the refrigerator section is not working.

- Was the refrigerator section door left open for too long? The lighting switches itself off automatically after approx. 15 minutes.

If this is not the case, then the lamp is defective:

- Disconnect the appliance from the mains. Switch off at the wall and withdraw the plug from the socket, or disconnect the mains fuse or remove the screw-out fuse in countries where this is applicable.

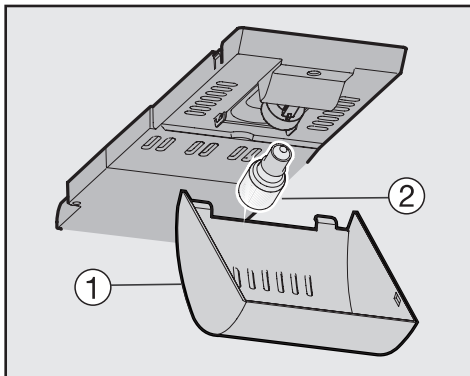

- Grip the lamp cover ① at the front and unhook it at the back.
- Unscrew the lamp ② and replace it with a new one.

Lamp specification:

220 - 240 V, E 14 fitting

See the old lamp for the Wattage required.

- Replace the lamp cover ①.

. . . the floor of the refrigerator is wet.

The drain hole is blocked.

- Clean the condensate channel and drain hole.

If you still cannot remedy the fault having followed these suggestions, please contact the Miele Service Department.

To prevent unnecessary loss of temperature it is advisable not to open the doors while waiting for the appliance to be serviced.

Noises

Normal noises	What causes them
Brrrrr...	Humming noise made by the motor (compressor). This noise can get louder for brief periods when the motor is switching on.
Blubb, blubb....	A gurgling noise can be heard when coolant is circulating through the pipes.
Click....	Clicking sounds are made when the thermostat switches the motor on and off.
Sssrrrrr....	On multi-zone and frost-free appliances you can sometimes just hear the movement of air circulating inside the appliance.

Remember that the noise of the compressor and the coolant circulating in the system is unavoidable.

Noises that you can easily rectify	What causes them, and what can you do about them?
Rattling, vibrating	The appliance is uneven: Realign the appliance using a spirit level, by raising or lowering the screw feet underneath the appliance.
	The appliance is touching another appliance or piece of furniture: Move it away.
	Drawers, baskets or shelves are unstable or sticking: Check all removable items and refit them correctly.
	Are any bottles or containers unstable or knocking against each other? Separate them.
	The transport cable clips are hanging loose at the back of the appliance: Remove the clips.

In the event of a fault which you cannot correct yourself, or if the appliance is under guarantee, please contact:

– your Miele Dealer

or

– Miele
(see back cover for contact details).

When contacting your Dealer or Miele, please quote the model and serial number of your appliance. This information is given on the data plate inside your appliance.

Please note that telephone calls may be monitored and recorded for training purposes.

N.B. A call-out charge will be applied for service visits where the problem could have been resolved as described in these instructions.

Guarantee

For information on the appliance guarantee specific to your country please contact Miele. See back cover for contact details.

In the U.K. your appliance is guaranteed for 2 years from the date of delivery. However, you must activate your cover by calling 08706 080028 or registering online at www.miele.co.uk.

Electrical connection

Electrical connection U.K.

All electrical work should be carried out by a suitably qualified and competent person in strict accordance with current local and national safety regulations (BS 7671 in the UK).

The appliance is supplied with a mains cable and moulded plug ready for connection to an a.c. single phase 220-240 V 50 Hz supply.

Please ensure that the connection data quoted on the data plate match the household mains supply.

Connection should be made via a suitable switched socket which is easily accessible. For extra safety it is advisable to install a suitable residual current device (RCD).

Do not connect the appliance to the mains electricity supply by an extension lead. Extension leads do not guarantee the required safety of the appliance (e.g. danger of overheating).

The appliance must not be connected to an inverter and must not be used with a plug adapter as these can cause damage to the appliance's electronic unit.

Non-rewireable plugs (BS 1363)

The fuse cover must be re-fitted when changing the fuse, and if the fuse cover is lost, the plug must not be used until a suitable replacement is obtained. The colour of the correct replacement cover is that of the coloured insert in the base of the plug, or the colour that is embossed in words in the base of the plug (as applicable to the design of the plug fitted).

Replacement fuses should be ASTA approved to BS 1362 and have the correct rating. Replacement fuses and fuse covers may be purchased from your local electrical supplier.

WARNING
THIS APPLIANCE MUST BE
EARTHED

Do not place any appliance which gives off heat, such as a toaster or microwave oven, on top of this appliance, as this would increase the appliance's energy consumption.

This appliance must not be installed directly next to another refrigerator or freezer.

It does not have side-wall heating, so installation next to another refrigerator or freezer could cause a build-up of condensation between them.

Further information is available from your dealer.

Important: tropical / humid environments

During periods of high humidity, some condensation may appear on outside surfaces of cooling appliances. This condensation will disappear when humidity levels drop. For prevention, it is advisable to install the appliance with sufficient ventilation in a dry and/or an air-conditioned room.

Please ensure that doors are closing and sealing properly.

Please ensure that the appliance is installed in accordance with these installation instructions and that the handle is fitted correctly. Should you require further assistance please contact your Miele customer service centre.

Location

This appliance should be installed in a dry, well-ventilated room. It should not be installed where it is exposed to direct sunlight or directly adjacent to a heat-producing appliance such as an oven or a radiator. The room temperature should not go above or below the climate range for which the appliance is designed. The higher the ambient temperature of the room, the more energy the appliance requires to operate.

Installation

Climate range

The appliance is designed for use within certain climate ranges (ambient temperatures), and should not be used outside this range. The climate range of the appliance is stated on the data plate inside the appliance.

Climate range	Ambient room temperature
SN	+10°C to +32°C
N	+16°C to +32°C
ST	+16°C to +38°C
T	+16°C to +43°C
SN-ST	+10°C to +38°C
SN-T	+10°C to +43°C

Operating in a room which is too cold will cause the cooling system to switch off for too long, causing the internal temperature in the appliance to rise with the risk of frozen food deteriorating and going off.

Ventilation

Air at the back of the appliance gets warm. To ensure sufficient ventilation, the ventilation gaps must not be covered over. The air inlet and outlet must not be covered or blocked in any way. They should be dusted on a regular basis.

Installation

- Remove the cable clip from the back of the appliance.
- Check that all parts at the back of the appliance are unhindered. Carefully remove any hindrance.
- Carefully push the appliance into position with the back against the wall.

Aligning the appliance

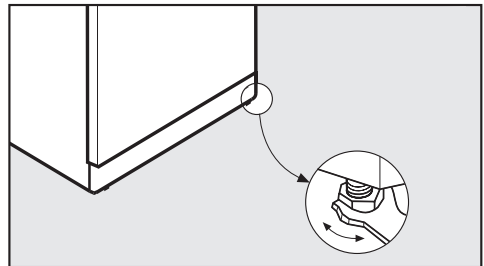

- To align the appliance, adjust the feet using the spanner supplied.

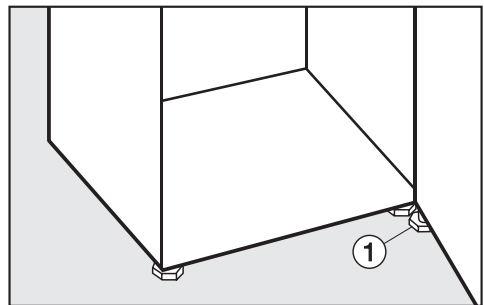

- Also unscrew support ① from the bearing block, to level the appliance door.

Appliance dimensions

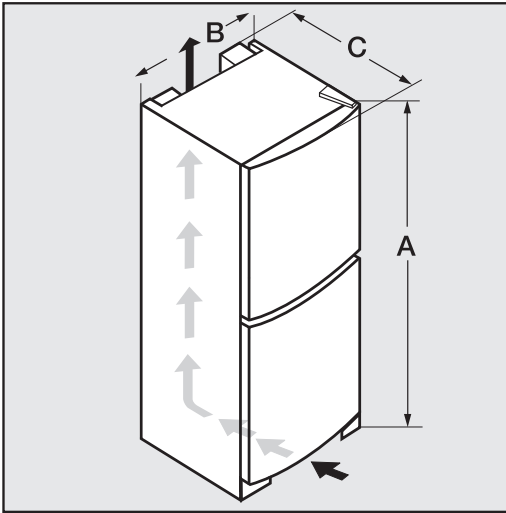

	A	B	C
KFN 12823 SD	1820 mm	600 mm	630 mm
KFN 12923 SD, KFN 12924 SD	2010 mm	600 mm	630 mm

Changing the door hinging

The appliance is supplied right-hand hinged. If left-hand door hinging is required, follow the instructions below.

To change the door hinging you will need the following tools:

- a cross-slotted screwdriver,
- a flat-bladed screwdriver,
- a selection of Torx screwdrivers,
- a spanner.

Two people are needed for changing the door hinging.

Removing the door handles:

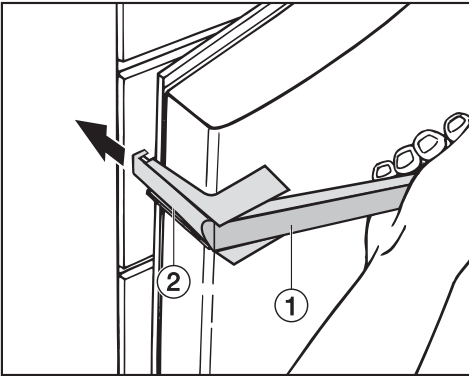

- Pull door handle ① towards you. Side section ② slides back.
- Pull side section ② out of the guides on the mounting plate.
- Undo the 4 screws (Torx 15) in the mounting plate, and remove the handle.
- Remove the cover caps from the opposite side, and fit them into the empty holes.

Changing the door hinging

To remove the doors:

Make sure the door shelves are empty.

- Close the upper door.

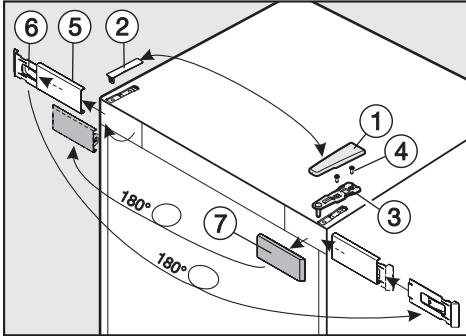

- Remove cover ① by sliding it forwards from the back and then lifting it off.
- Remove cover ② by pulling it upwards.

Caution. The upper door is not secure as soon as the upper hinge plate is removed.

- Loosen screws ④ in upper hinge plate ③ and pull it upwards and off.
- Carefully lift the upper door off and place it to one side.
- Carefully loosen cover ⑤ from above using a screwdriver and then take it off together with retaining plate ⑥.
- Then separate retaining plate ⑥ from cover ⑤, by pushing it slightly to the left. Then pull the cover forwards and off.
- Rotate retaining plate ⑥ by 180°.

- Then fit cover ⑤ from the front over retaining plate ⑥, and slide it over to the right. The writing must be visible.
- Remove cover ⑦, then rotate it by 180° and fit it on the opposite side.
- Then fit cover ⑤ together with retaining plate ⑥ on the opposite side.

Changing the door hinging

- Close the lower appliance door.

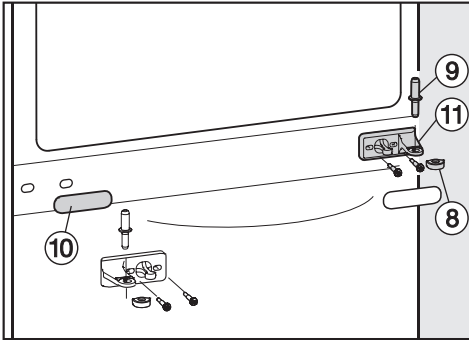

- Pull plastic cover (8) off.
- Pull the middle hinge pin (9) upwards to remove it.
- Carefully lift the lower door off and place it to one side.
- Pull cover (10) off.
- Unscrew hinge plate (11), turn it through 180° and fit it on the opposite side.
- Turn plastic cover (8) 180° and refit it in the centre of hinge plate (11).
- Refit cover (10) on the opposite side.

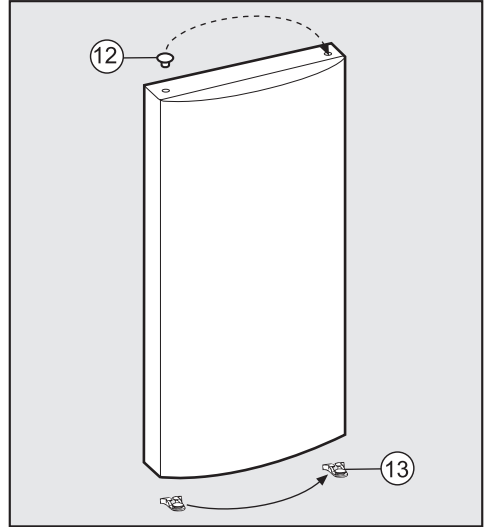

- Remove cap (12) from the bearing bush in the door and refit on the opposite side.
- Remove spring clamp (13) from underneath the door and fit it on the opposite side.

Changing the door hinging

Changing over the doors:

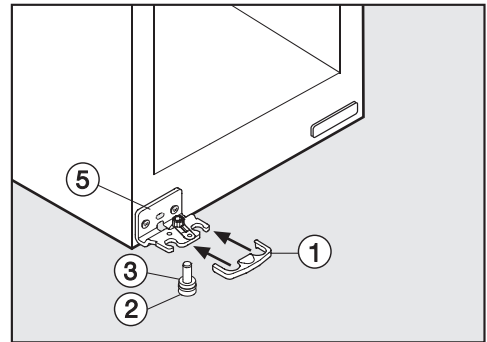
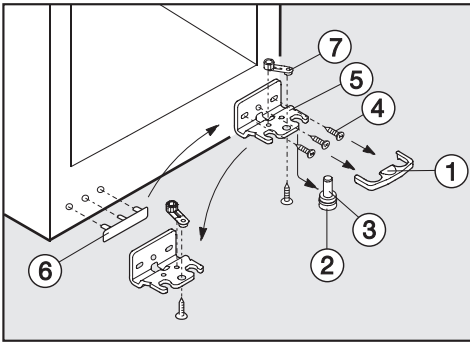

- Remove cover ① by pulling it forwards.
 - With the help of another person, carefully tilt the appliance backwards and pull hinge pin ② out.
 - Do not lose hinge bush ③.
 - Undo screws ④ and take hinge plate ⑤ off.
 - Remove cover ⑥ and fit it into the holes on the opposite side.
 - Unscrew bearing ⑦ from hinge plate ⑤ and screw it into the hole on the other side of hinge plate ⑤.
- Screw hinge plate ⑤ into position on the opposite side using the two **outer** long slots only. Do not use the middle hole because you will not be able to align the door later on.
 - Using a second person, carefully tip the appliance backwards and then fit hinge pin ② together with hinge bush ③ from below into hinge plate ⑤ on the left hand side.
 - Refit cover ① on the left.
 - Place the lower door onto hinge pin ②.
 - Close the lower appliance door.
 - Fit hinge pin ⑨ into middle hinge plate ⑪ in the lower door.
 - Then fit the top door on middle hinge pin ⑨.

Changing the door hinging

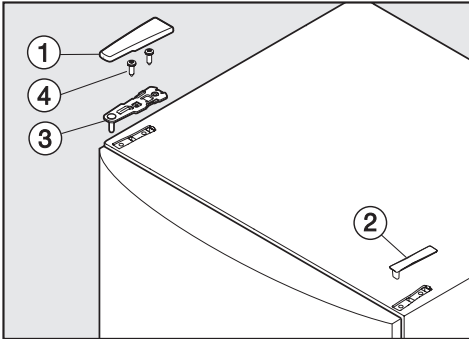

- Fit hinge plate ③ onto the opposite side and secure it with screws ④. If necessary drill pilot holes for the screws or use a battery operated screwdriver.
- Fit covers ① and ② to their opposite sides.
- Align the door with the appliance housing using the long slots in the lower hinge plate. Then tighten the screws.

Refitting the handle:

Please make sure you follow the instructions below carefully when you refit the handle. The door seal will be damaged if the handle is fitted incorrectly.

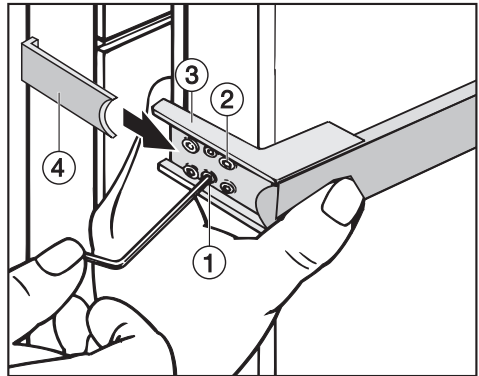

- Loosely attach the handle to the opposite side of the door with the two front screws ②.

Mounting plate ③ must be positioned on the side of the door so that when the door is **closed** it is flush with the side of the appliance.

If this is not the case,

- tighten both grub screws ① with a suitable allen key until mounting plate ③ lines up correctly.
- Then tighten all 4 fixing screws ②.
- Slide the side section of the handle ④ into the guides on the mounting plate until it clicks into place.

It is important to check that the side section of the handle ④ does not come into contact with the door seal when opening the door, as this would damage the door seal permanently.

If, after you have refitted the handle, you find that the side section does touch the door seal when the door is opened:

Realign mounting plate ③ with grub screws ① until the mounting plate and the side section of the handle ④ are at the correct angle and the side section does not touch the door seal when the door is opened.

Aligning the appliance doors

The appliance doors can be aligned with the housing at a later date.

In the following illustration the door is not shown in the closed position to make it easier to see what happens next.

To align the **lower door** use the long outer slots in the lower hinge plate:

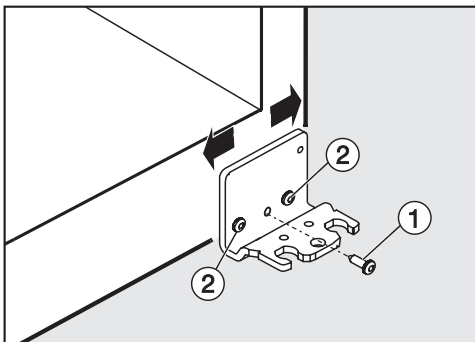

- Remove centre screw ① from the hinge plate.
- Slightly loosen both outer screws ②.
- Align the door by sliding the hinge plate to the left or right.
- Then tighten screws ② again. Screw ① does not need to be refitted.

To align the **upper door** use the long outer slots in the middle hinge plate:

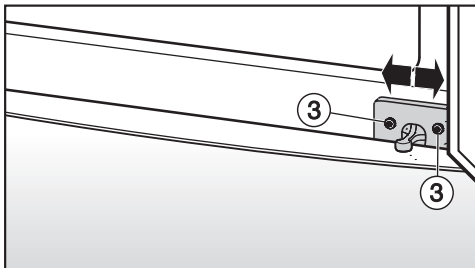

- Remove centre screw ① from the hinge plate.
- Slightly loosen both outer screws ②.
- Align the door by sliding the hinge plate to the left or right.
- Then tighten screws ② again. Screw ① does not need to be refitted.

Building in the appliance

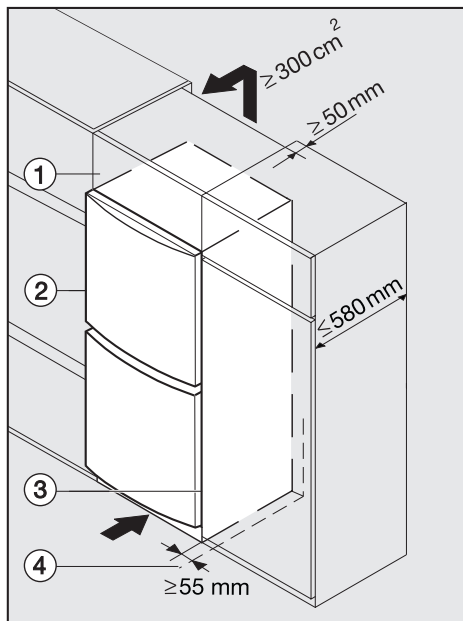

The air inlet and outlet must not be covered or blocked in any way. They should be dusted on a regular basis.

When built into a kitchen run (max. depth 580 mm) the appliance can be installed directly next to a kitchen furniture housing unit. The appliance door will protrude in front of furniture fronts at the sides by 34 mm and by 55 mm in the middle of the door. This enables the doors to be opened and shut without being obstructed.

When installed **next to a wall** ④ a distance of approx. 55 mm must be maintained on the hinge side between the wall ④ and the appliance ②, so that the doors and the handles have sufficient space for opening.

- ① Top box
- ② Appliance
- ③ Housing unit
- ④ Wall

The appliance can be installed in a kitchen run. To match the height of the rest of the kitchen, the appliance can be fitted with a suitable top box ①.

A ventilation gap of at least 50 mm depth must be allowed for behind the appliance across the entire width of the top box for air to circulate.

The cross section of the air outlet under the room ceiling must be at least 300 cm² to ensure that air can circulate without hindrance. Otherwise the appliance has to work harder, resulting in an increase in electricity consumption.

Miele

United Kingdom

Miele Co. Ltd.
Fairacres, Marcham Road
Abingdon, Oxon, OX14 1TW
Tel: 0854 365 0555
Fax: 0845 365 0777
Customer Contact Centre Tel: 0845 365 6600
E-mail: info@miele.co.uk
Internet: www.miele.co.uk

Australia

Miele Australia Pty. Ltd.
ABN 96 005 635 398
1 Gilbert Park Drive, Knoxfield, VIC 3180
Tel: (03) 9764 7130, Fax: (03) 9764 7149
Internet: www.miele.com.au

China

Miele Shanghai
Suite 4105-06, Plaza 66
1266 Nanjing Road West
Jing An District
Shanghai 200040, PRC
Tel: +86 21 6288 4200, Fax: +86 21 6288 4100
E-mail: mieleshanghai@cn.miele.com
Internet: www.miele.cn

Hong Kong

Miele (Hong Kong) Limited
AIA Plaza, 24th Floor
18 Hysan Avenue
Causeway Bay
Tel: +852- 2610-1331, Fax: +852-2610-1013
E-mail: mielehk@miele.com.hk
Internet: www.miele.hk

India

Miele Appliances India Pvt. Ltd.
Ground Floor, Copia Corporate Suites
Plot No. 9, Jasola
New Delhi – 110025
Tel: 011-46 900 000, Fax: 011-46 900 001
E-mail: customer care@miele.in
Internet: www.miele.in

Ireland

Miele Ireland Ltd.
Broomhill Road, Tallaght, Dublin 24
Tel: (01) 461 0710, Fax: (01) 461 07 97
E-Mail: info@miele.ie
Internet: www.miele.ie

New Zealand

Miele New Zealand Limited
Unit L, 10-20 Sylvia Park Road
Mt. Wellington, 1060, Auckland, NZ
Tel: 0800 264 353, Fax: 0800 463 453
Internet: www.miele.co.nz

Singapore

Miele Southeast Asia
Miele Pte. Ltd.
163 Penang Road
04 - 02/03 Winsland House II
Singapore 238463
Tel: +65 6735 1191, Fax: +65 6735 1161
E-Mail: infosea@miele.com.sg
Internet: www.miele.sg

South Africa

Miele (Pty) Ltd
63 Peter Place, Bryanston 2194
P.O. Box 69434, Bryanston 2021
Tel: +27 (0) 11 548-1900
Fax: +27 (0) 11 548-1935
E-mail: info@miele.co.za
Internet: www.miele.co.za

United Arab Emirates

Miele Appliances Ltd.
P.O. Box 11 47 82
Gold & Diamond Park
Sheikh Zayed Road
Building 6 / Offices Nos. 6-214 to 6-220
Dubai
Tel: +971-4-341 84 44
Fax: +971-4-341 88 52
E-Mail: info@miele.ae
Internet: www.miele.ae